

Planning
Installation
and
Maintenance
Guide

Ultrawall[®]

Relocatable Partitions

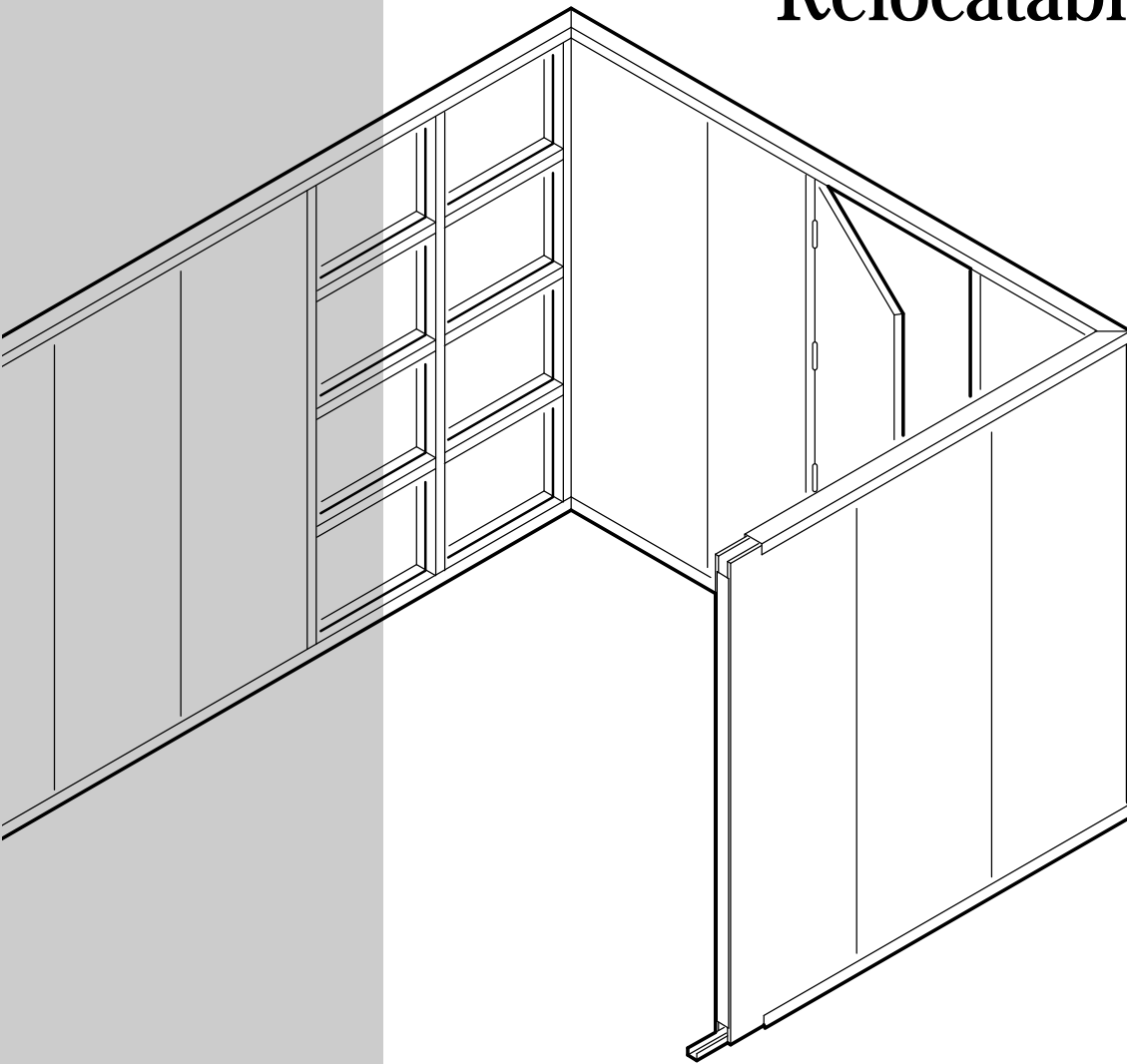

U / WLLC

Table of Contents

Tool List	3
Ceiling Track Installation	4-5
Floor Runner Installation	6-7
Vertical Strut Runner Installation	8-10
Panel Support	10
T-Intersections	11
Stud Installation	12-14
Corner Detail	15
Door Frame Installation	16-17
Glass Opening Construction	18-20
Trim Options	21
Furred Panels	22-23
Electrical Installation	24-26
Panel Replacement	27
Maintenance Instructions	28

Planning Installation and Maintenance Guide

Careful planning is a key to successful interior design. This is particularly true with prefinished systems. Such planning requires an in-depth knowledge of connection details for attractive implementation.

ULTRAWALL® relocatable partitions provide the look and feel of permanence along with ease of relocation and reuse. Locate door openings, sidelites, even full glass walls wherever you want them.

This Guide provides step-by-step directions for the installation of ULTRAWALL partitions beginning with four basic components—ceiling track, floor runner, spline stud and 3/4" gypsum panel.

This Guide also covers installation of doors, windows, trim, finishing details and replacement practices that result in a quality, custom appearance.

Before finalizing the design of any project utilizing ULTRAWALL partitions, be sure that current and future plans for flooring, ceiling, lighting, communications, and HVAC are considered.

Tools	Hammer	4' Level
	Tape Measure	Chalk Line
	Board Knife	Caulking Gun
	Screwdrivers	Electric Drill
	Pliers	Drill Bits
	Wallboard Saw	Ladder
	Combination Square	Chop Saw (Power Miter Box), Aluminum Cutting Blade
	Wallboard Square	Files
	Electric Screw Gun	Screw Gun Bits (Phillips #2 & #3)
	Tin Snips	Hacksaw
	Plumb Bob	Center Punch

Optional Tools	Shop Vacuum	Panel Removal Tool
	Hot Knife	2' & 6' Levels
	Hole Saw	Torpedo Level
	Chassis Punch	Concrete Fastener Tool
	Scaffold	"C" Clamp Vice Grips
	Rubber Mallet	Safety Glasses

(Note: Please Wear Safety Glasses.)

Ceiling Track Installation

Ceiling Track may be either aluminum or steel depending on cost and aesthetic preferences. The following instructions describe all systems, beginning with the aluminum materials.



1. Position ceiling track (ARL-300, ARL-301, STL-362) at appropriate location on ceiling (according to required partition layout).



2. Securely attach ceiling track to ceiling grid with screws or other appropriate fasteners located 24" to 48" o.c. or as required by governing code body.



3. Join aluminum ceiling tracks by inserting splicing pins—SCL-382, approximately half way, into upper right and left holes at end of installed ceiling track.



4. Tap pins with hammer so that they fit snugly into holes.



5. Connect next ceiling track section by inserting exposed portions of splicing pins (on ends of installed runner) into empty holes of ceiling track being installed.
Note: Aluminum ceiling track—Use 2 SCL-382 splice pins; Steel ceiling track—Use SCL-385 splice clip.

Continued

After all parallel ceiling tracks have been installed in a particular area, install cross tracks in the same manner. Here are a few tips.

Tips



6. To join T-intersections, screw-attach angle clip to ceiling track as shown.



7. To make square corners with aluminum ceiling track, miter ARL-300 components and join with SCL-383 corner clip.

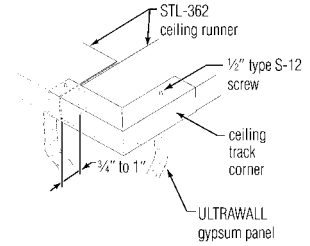

8. To make square corners with steel track, butt square-cut STL-362 members and cap outside corner with Steel ceiling track corner.



9. A special corner piece, ACR-714 round ceiling track corner, is used with aluminum ARL-300 and ARL-301 tracks.



10. Join corner piece to ceiling track using SCL-382 splice pins.

Floor Runner Installation

After the ceiling runner is installed, install the floor runner. Protective plastic may be used to cover floors prior to installation. Plumb down from ceiling runner to establish location of floor runners.



1. Layout marks can be placed on masking tape; chalk lines can be snapped directly on floor or covering plastic.



2. Floor runners can be attached with mechanical fasteners or SCL-384 carpet grippers, designed for use with most commercial grades of carpet. To secure STL-361 floor runners to carpet, first friction fit SCL-384 carpet gripper to bottom side of floor runner 24" o.c.



3. Attached carpet gripper will look like this.



4. Place floor runner with carpet grippers on carpet as planned. Carpet grippers will minimize cleanup when partitions are moved. SCL-384 carpet grippers are often placed at each panel joint.



5. To join two floor runners, slit runner webs down center line.



6. Intertwine runners.

Continued



7. Screw-attach runners together. After all parallel floor runners have been installed, cross runners should be installed to complete the floor runner installation.



8. At door openings and freestanding wall terminations, anchor floor runner to subfloor.



9. Use suitable fasteners for positive attachment.



10. At intersections of floor runners with carpet grippers, cut and flatten legs of one runner to accommodate lapping of runners and positioning of wall panels.



11. Screw-fasten runners.



12. Lap and join runners at corners in the same manner.



13. At floor runner intersections, floor runners can be secured directly to subfloor in lieu of screw-attaching them together. Note that intersecting runner is cut short to allow panel to pass through.

Vertical Strut Runner Installation

Vertical strut runners provide required strength and panel attachment capability at rough openings for doors, windows, corners and freestanding wall terminations.



1. For most vertical strut applications, a single STL-361 floor runner normally is used. Double STL-361S strut runners are recommended at door openings, especially where fire resistance is necessary. This strut is also used to construct corners, intersections and window rough openings. STL-361 runners must be installed with torque-sensitive screw fastening tools to ensure screw fasteners do not strip out.

For ARL-300 ceiling track, there are five methods of vertical strut runner attachment.



Method 1. Snip aluminum inner flanges to create a notch which will receive strut web.

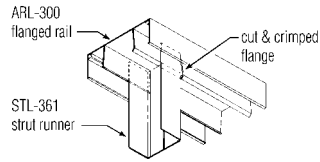

Bending aluminum flanges back in place will secure strut.



Method 2. Screw-attach sheet metal angle to both ceiling runner and strut.



Method 3. Cut and bend strut runner to overlap strut legs and inner flanges of ceiling runner. Screw-attach strut to ceiling runner at corners.



Method 4. Slit strut at its flange/web corners and fold web down. Strut flanges will overlap aluminum inner legs.



Method 5. Engage strut runner to stud extension and screw-attach through pre-punched holes in extension.



Plumb strut runner and screw-attach extension to ceiling track.

Vertical Strut Runner Attachment

For STL-362 ceiling track, there are two methods of strut runner attachment:



Method 1. Cut, bend and screw-attach end of strut runner into STL-362 ceiling track. For easy centering of strut, use two small pieces of panel.



Method 2. Engage strut runner to stud extension and screw-attach through pre-punched holes in extension.



Plumb strut runner and screw-attach extension to ceiling track.

Panel Support

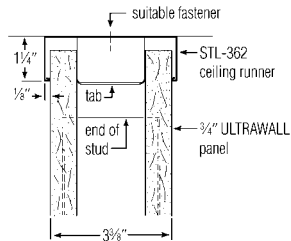

For STL-362 ceiling runner, panel support is provided by pulling down tabs at middle of each panel.

T-Intersections

There are two methods for constructing T-intersections for regular ULTRAWALL partitions.



Method 1. Position vertical strut runner at existing wall.



Fasten vertical strut from back side.

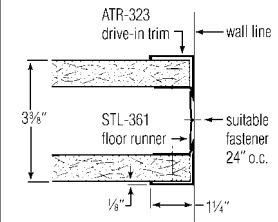

Screw-attach panels to strut in plumb position.



Method 2. Attach ARL-300 flanged rail to intersecting wall.

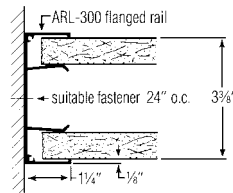

Flanged rail is ready to receive ULTRAWALL panel edges.



Secure intersecting ceiling runners with angle clip. Angle clip with longer leg can also be used to secure the stud assembly in the proper position.

Stud Installation

ULTRAWALL partitions have various stud types which afford different features and methods of panel installation. The H-stud is the most basic system. Both sides are progressively installed at the same time.

H-Studs



1. For standard ULTRAWALL H-stud partition erection insert pair of ULTRAWALL gypsum panels into ceiling runner and secure to vertical starting members. Leading panel edges must be square and plumb. If snap-on base is being utilized then fit base channel over bottom edge of panel prior to installation.



2. Shim leading edge of each panel to ensure tight panel joints.



3. Attach each panel to floor runner with two screws located within 6" of panel edges.



4. Install STL-360 steel H-stud with outer flanges engaging panel kerfs. Note that ends of stud can be up to 3" short of floor and ceiling.

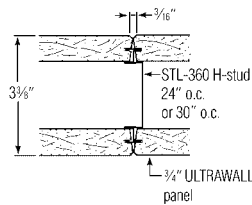

5. H-stud is installed 24" o.c. at each panel joint.



6. Tops of studs can be additionally secured with screw-attached stud extension. Flanges on extension must be formed to fit stud.

Continued



7. Continue installing ULTRAWALL panels and studs...



8. ...until partition is complete.

Stud Installation

T-stud systems allow each side to be installed independently. There are advantages and disadvantages to each type of system. The ultimate selection depends on the needs of the owner. The next section will cover the various installation steps for all of these ULTRAWALL partition systems.

T Studs



1. T-studs permit one side of the wall to be erected independently of the other side. The advantages of this type of partition include being able to install opposite faces of the dividing wall between leased areas at different times. Also, power lines and communication cable installation can be easily coordinated with partition installation.

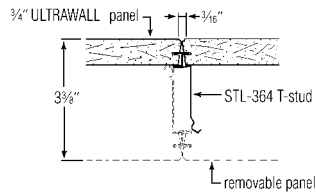

2. Panel joints in steel T-stud partitions can be directly opposed or offset.



3. Steel T-studs, similar to steel H-studs, can be short at top and bottom—up to 3".

Corner Detail

Conventional square corners are constructed with intersecting panels attached to two vertical strut runners.

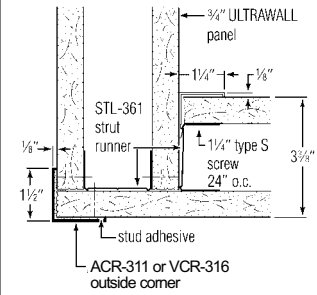

1. The inside corner detail can be finished with trim (as shown) or without.

2. Square outside corners require STL-361 strut runners.

Door Frame Installation

Once walls have been erected up to door location, door frames can be installed.



1. Some door frames require preassembly of bumper mute.



2. Upon preassembling components, place hinge jamb on wall.



3. Screw-attach jamb at top only.



4. To plumb the hinge jamb, suspend plumb bob from ceiling runner and measure distance from door jamb to plumb bob string at top and bottom.



5. Reposition bottom of door jamb to be equidistant top and bottom. Screw-attach remainder of door frame to partition starting at the bottom.



6. Snap header into ceiling track tight to hinge jamb.

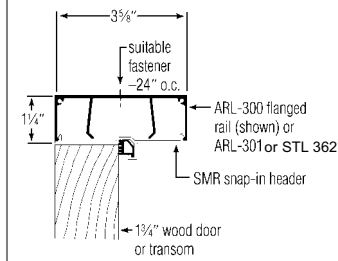

7. Door with installed hinges is propped in place adjacent to hinge jamb, and screw-attached to door jamb.

Continued



8. Sections of mortised trim are cut and snapped in place to fill above and below all hinges.

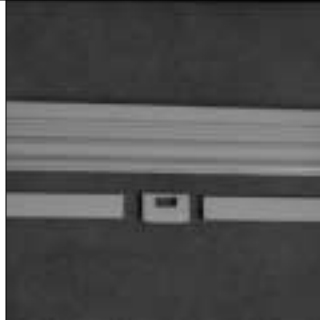

9. Mortised trim and snap-in strike plate can be cut...



10. ...and mounted to strike jamb prior to installation.



11. Strike jamb must be positioned to ensure proper door closure and securely fastened.



12. Door frame is secured to partition.

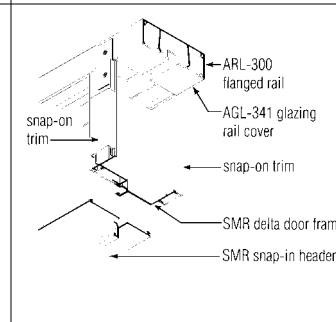

13. SMR door frames installed with adjacent glazing require attachment of jamb member to ceiling track using flat clips. See diagram for detail.

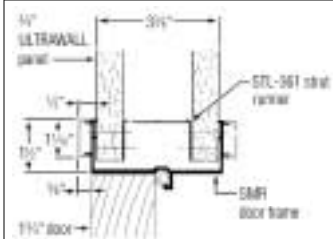





14. Door frames less than ceiling height require different header assembly which is installed on partition similar to door jamb installation.

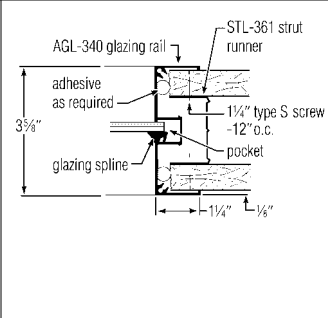
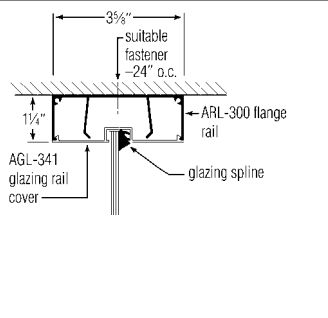

15. Snap-on trim conceals all fasteners.

Glass Opening Construction

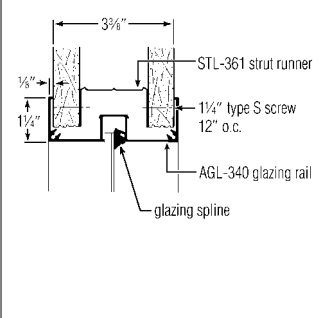
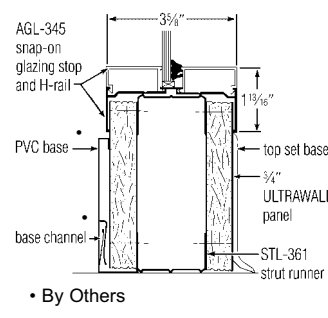
Full height glass openings require capping partition with AGL-340 glazing rail.

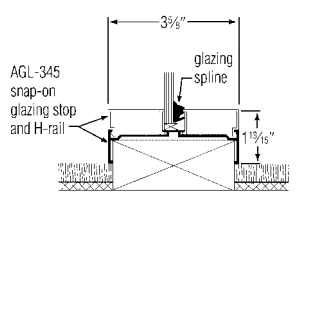
		
<p>1. Pocket of component is designed to receive 1/4" thick glass.</p>	<p>2. Use of adhesives or setting type joint compounds can prevent movement of glazing rail during installation of glass.</p>	<p>3. Glass extending to ceiling is contained by AGL-341 glazing cover.</p>
		 <p>• By Others</p>
<p>4. Cover is snapped into ceiling runner.</p>	<p>5. Glass openings with solid partition above them require AGL-340 glazing rail to cap panels and receive glass.</p>	<p>6. Sill conditions at floor lines are constructed differently. A built-up sill can be constructed as a small partition or from stacked wood blocks.</p>
		
<p>7. A built-up sill allows base to extend beneath sill trim components.</p>	<p>8. Vertical glazing rails can extend to floor and built-up sill is constructed between them.</p>	<p>9. Sill components can be installed over single wood block, lowering glass line closer to floor.</p>

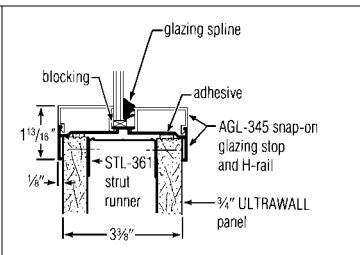

10. Borrowed light opening, which is a window not extending to the floor or ceiling, requires a sill constructed in similar manner with AGL-345 assembly...

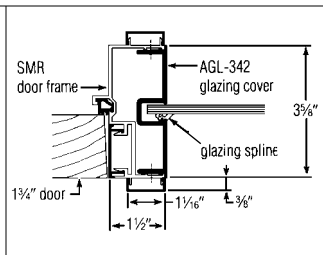

11. Full height glass openings adjacent to door frames require reinforcement of the door jamb member with the AGL-342 door frame glazing cover.



12. AGL-342 door frame glazing cover is snapped into door jamb and screw-attached.

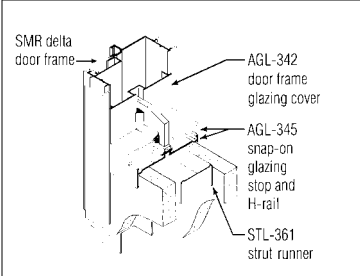

13. Less than full height glass openings not requiring additional reinforcement of door jamb can be trimmed with AGL-341 glazing cover.



14. Narrow panels adjacent to large openings can be secured with angle clips.



15. Clips are screw-attached within ceiling runner to wedge against panels.



16. Large glass openings divided by vertical mullions require continuous AGL-341 glazing cover to be snapped into ceiling runner.



17. After continuous sill rail is installed, AGL-342 door frame glazing cover is secured to door jamb as previously described.

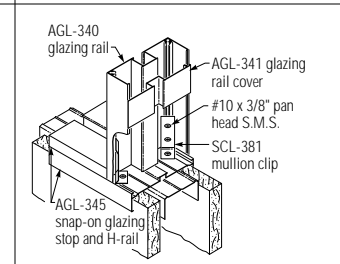

18. Vertical glazing mullions are constructed with AGL-340 glazing rail and AGL-341 glazing cover.

Glass Opening Construction

Continued



19. SCL-381 mullion clips are screw-attached to both ends of AGL-340 glazing rail.



20. Position glazing rail plumb and square...



21. ...and screw-attach top and bottom.



22. AGL-341 glazing cover is snapped into AGL-340 glazing rail to complete mullion.

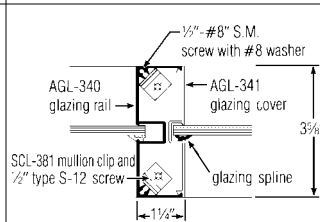

23. Use #8 S.M. screw with #8 washer to secure mullion clips to glazing rail.

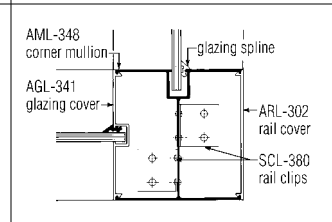

24. Corners are constructed with corner mullion secured at top and bottom with rail clips.



25. Glass stops are marked for tight fit...



26. ...cut to length...



27. ...and secured to sill.

Trim Options

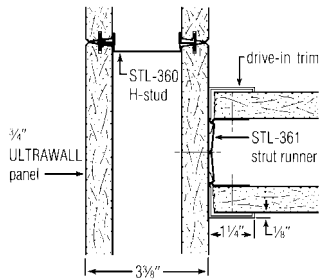

1. Drive-in trims conceal screw heads and provide finished appearance at inside corners.

Another way to finish an inside corner condition is to use the factory edge of the panel as the finished corner. Secure panel to strut runner with adhesive.



2. Use either aluminum ATR-323 or vinyl VTR-325 drive-in trim for this application. Aluminum drive-in trim can be specified with anodized or painted finish.



3. Vinyl trim is available in several solid colors or laminated to match wall panels.



4. Component is positioned against ceiling track and lightly tapped in place.



5. Round or square outside corner trims provide a variety of appearances. Aluminum ACR-311 and vinyl VCR-316 square corners are also available with the same finishes as drive-in trims.

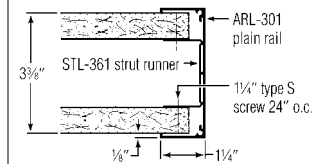

6. Freestanding wall terminals are trimmed with ARL-301 plain rail which caps partition end. Component is available in either anodized or painted finish.

Furred Panels

Furred application of ULTRAWALL panels can be installed over existing wall surfaces to provide continuity in appearance and function.

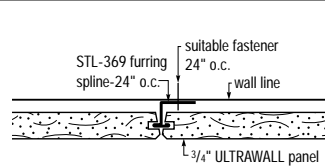

1. Additional furred layer of ULTRAWALL panels is installed on one side of basic ULTRAWALL partition to obtain two-hour fire rating or 50 STC sound rating.

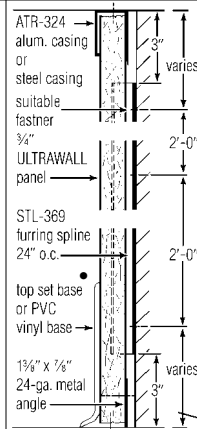

2. Aluminum casing may be used.

• By others



3. Trim is secured to ceiling with front leg of trim spaced 1" from wall surface. Backing strips should be provided as required.



4. Top of panel is inserted into casing trim.



5. Panel is slid over to engage furring spline.



6. Furring spline is engaged with kerfed panel edge.



7. Spline is secured to wall surface with appropriate fasteners. Some shimming may be required to eliminate irregularities in flatness of existing wall.



8. Horizontal furring members will provide secure attachment of vertical furring splines where locations of furring splines do not coincide with wall studs.



9. Top of panel is inserted into casing trim...



10. . . . and is slid over to abut intersecting wall.



11. Vertical furring splines are positioned . . .



12. . . . and screw-attached to horizontal furring members.



13. 1/4-in. wood strips are applied to face of existing wall to provide backing to panels at base. A 1-3/8"x7/8"x 24 ga. metal is required at the base for fire rated construction.



14. Offset wall planes can be hidden by intersecting walls or trims.



15. ULTRAWALL partition, constructed with T-studs and panels on one side only, provides furred wall system independent of existing wall. Insulation can be installed between two walls. Either STL-362 ceiling track or ARL-300 flanged rail can be used as ceiling runner.



16. Ceiling runner can be notched to fit around building columns.



17. Top and bottom of T-studs can be secured with angle clips to increase partition rigidity.



18. Supplemental horizontal members angle clipped to T-studs are required for partition rigidity.

Electrical Installation

Electrical outlets and switches are easily accommodated in ULTRAWALL partitions with conventional electrical components. These photographs illustrate various means of providing structural support for electrical boxes to meet building code approval.

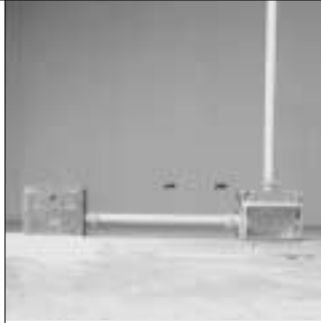

1. For minimum acoustical transmission, back-to-back outlets should not occur within a common partition cavity.



2. Separating outlets to fall into adjacent cavities improves this condition.



3. A vertical piece of strut runner can be used to support electrical boxes.



4. A saddle can also be fabricated from strut runner for electrical box support.



5. In some areas electrical boxes can be located in the floor track.



6. A piece of conduit can be coupled to the electrical box for support.



7. Flexible prewired electrical systems can also be used in ULTRAWALL partition systems. Photo illustrates one side of wall erected with T-studs prior to electrification.



8. Flexible prewired electrical components can also be installed through ceiling runner prior to erecting any panels..



9. Plug-in connector for this type of electrical system is inserted through hole in ceiling runner...



10. ...and mating hole in ceiling tile.



11. Electrical boxes with flanged brackets are easily screw-attached into floor runners.



12. Outlets occurring in adjacent wall cavities can be handled by independent cables dropped from above ceiling...



13. ...and routed to box at floor.



14. Electrical boxes for wall switches are easily secured to the panel by means of expansion anchorage provided on box or separate sheet metal clips.

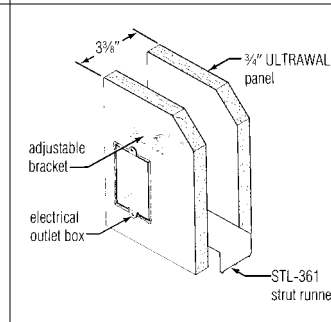

15. Reversing the adjustable brackets on a conventional electrical box allows it to be inserted through the back of the panel and sandwiched in the cavity when the opposite panel is installed.



16. Flexible electrical systems can be routed to provide electrical outlets...



17. ...in sill area of glazed opening.



18. For increased sound isolation, cavity of partition is filled with insulation cut to fit tightly around all studs and electrical components.

Electrical Installation

Continued



19. Measurements must be taken for openings to be cut in panels receiving electrical boxes.



20. Reference locations such as floor surface or panel edges are very helpful.



21. Measurements for box opening are then transferred to face of panel.



22. Wall board saw is used to easily cut required opening.



23. When cutting openings in fabric-covered panels, be sure to prevent gypsum dust from getting into pores of material.



24. A shop vacuum following cut will minimize dusting on panel surface.



25. Some fabrics may require precutting and removing the fabric to prevent snagging.

Panel Replacement

ULTRAWALL panels installed with H- or T- studs are easy to remove and replace if panels are damaged or to gain access to partition cavity.



1. The first step in removing a panel is to cut a 2" section across panel width along bottom.



2. Only one corner of this strip is pulled out in order to prevent panel from dropping.



3. Opening allows grasping bottom of panel near one edge in order to peel it out of wall. This action breaks the back of kerfed edge of panel.



4. Full removal of the strip at bottom allows panel to drop out of ceiling runner. Slide the panel sideways to disengage opposite kerf from stud.



5. Cut off broken portion of kerfed edge of existing panel or remove back kerfed portion of one edge of a new panel.



6. Nest a piece of STL-361 strut runner with inner flanges of stud.



7. Tap into place.



8. Apply construction adhesive to exposed flange of strut runner.



9. Then replace old or new panel in reverse order of above procedures.

Maintenance Instructions

I. Product Furnished

A. Vinyl on Gypsum

II.

The following is manufacturer recommendation for cleaning and maintenance of the following product:

A. Vinyl on Gypsum

Use a soft bristle brush with a warm solution of a non-abrasive detergent and tri-sodium phosphate. Add 1/3 cup of detergent and 2/3 cup of TSP to one gallon of warm water and apply to wall with a soft bristle brush (do not use cloths). When clean, rinse with fresh water. For trouble spots, we recommend any household cleaner that does not contain any solvents, thinners or other ingredients that might harm the vinyl. The use of such products must be in full accordance with the instructions on the label.

Trademarks

The following are trademarks of USG Interiors, Inc. or a related Company: ULTRAWALL, USG.

Notice

We shall not be liable for incidental and consequential damages, directly or indirectly sustained, nor for any loss caused by application of these goods not in accordance with current printed instructions or for any other than the intended use. Our liability is expressly limited to replacement of defective goods. Any claim shall be deemed waived unless made in writing to us within thirty (30) days from date it was or reasonably should have been discovered.

Note

All products described here may not be available in all geographic markets. Consult your local sales office or representative for information.